

TS-60 Power Sprayer Manual

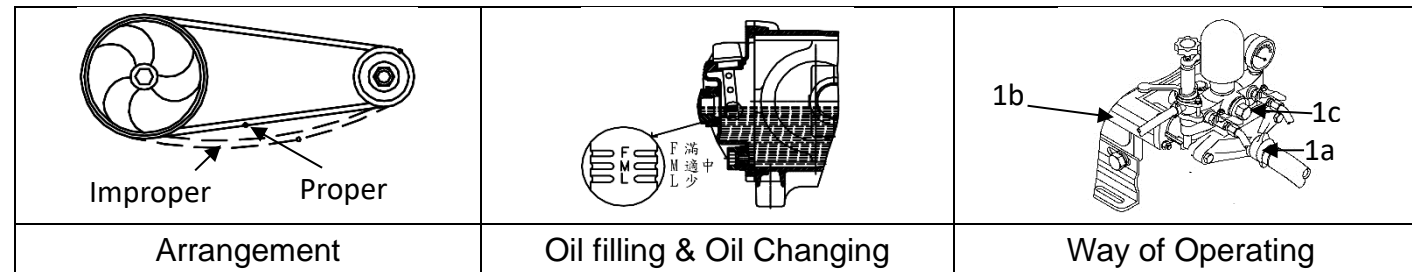

1. Arrangement

Adjust the belt and pulley in order to make the belt straightly. The V-belt must not be set loosely as to slip away or drop out of its position.

2. Oil Filling & Oil Changing

Fill #30 or #40 Oil through the oil hole. Keep the oil level just half of the oil gauge. Change the oil after 50 hours use for the first time and every 100 hours since then. The proper time for changing oil is after operating and the machine is still warm. Remove the drain plug and begin draining.

3. Grease Filling

The three grease cups on the cylinder must always be filled with grease. After using for every two hours, wind the grease cups about two circles per time.

4. Spray

- Fix firmly the suction hose (1a), overflow hose (1b) and spraying hose (1c) on the suction metal, over flow body and cock respectively. Make sure they must be set firmly and let no air leak out.
- Operate the power and start the power sprayer.
- Turn off the cock.
- After the power sprayer is normally operating, adjust the pressure screw. Then turn on the cock and begin operating the power sprayer.

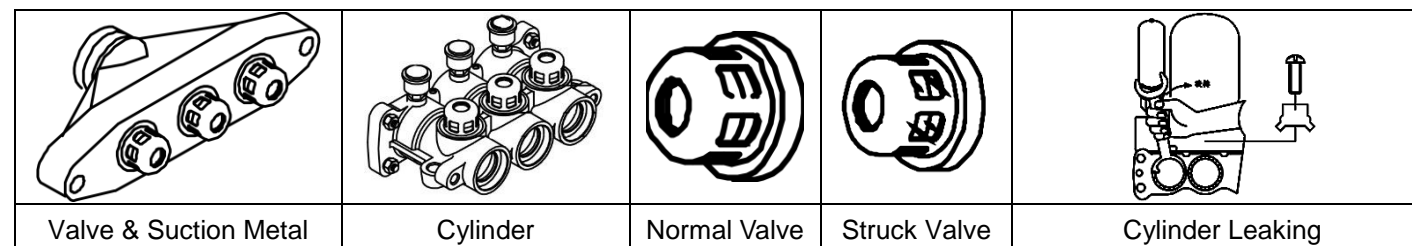

5. Trouble Shooting

- Feeding failure & pressure instability :
 - Check whether the suction hose is any leaking of air. Tight it up.
 - Check whether the strainer is stuck. Clean it up, if necessary.
 - Turn on the cock for a little while to let out the air left in the feeder and then turn it off.
 - Check whether the suction metal, cylinder and six valves are stuck. Clean it up, if necessary.
 - Check the flat valve and valve seat to see whether they are damaged.
 - Check whether the valve springs are damaged.
- Cylinder Leaking :
 - Take the stopper away from the cylinder with screw driver.
 - Remove the plunger cover and wind by the three grands on the cylinder (for 1/3 round ~ 1/2 round). If leaking is still uncontrollable, change the V-packing in the cylinder.
- Pressure Falling :
 - Check whether the V-belt is loose.
 - Check whether the spraying hose and coupling packing of spraying hose are broken. Renew the parts if necessary.

6. Maintenance

- Operate the power sprayer with clean water for about 5 minutes after use in order to clean the pesticide left in the machine.
- Remove the suction hose, over flow hose, and spraying hose. Then wipe every part of the machine dry.
- Check the oil in the crank case. Refill oil, if necessary.
- Check whether every screw is set firmly.
- Check whether there is any leak of oil.

7. Caution

- During operation, please don't reach out your hands into space of revolving belt wheel to prevent you from being harmed.
- Please check if there is enough oil before operating machine.
- Please check if gasoline, diesel oil or cooling water are enough before operating machine.
- Please check if contact of electric source and insulation are under good condition before operating machine.
- The spraying machine sprayed by pesticide or chemical liquid is prohibited to be used for pumping water to prevent poison.
- Please renew pressure gauge if it is damaged in order to maintain machine's safety.
- Loosen pressure adjusting screw counterclockwise, after using this machine.

8. Warranty

- Warranty : This warranty involves any failure parts produced or supplied by manufacturer when failure part caused any abnormal performance. During warranty period, the manufacturer offer free maintenance.
 - No service charge and expense of replaced part are required with warranty.
 - Warranty period : One year after delivery.
- The manufacturer is not responsible for damage provokes in case of:
 - A serious lack of foreseen maintenance.
 - Damages caused by the nature disaster such as earthquake.
 - Modifications or intervention that are not authorized by the manufacturer.
 - Non-normative uses that contrary to the specific.
 - The use of non-original spare parts and assigned oil for the pump.
 - Natural aging situation such as rust on surface caused by time.
 - Not inquire to factory or your local distributor when damage occurs.
 - The performance is still good base on power sprayer's registered spec. even some noise or vibration show up.
 - Using the pump without following the instructions of this manual.
- The manufacturer is not responsible for expense provoked in case of:
 - Losing of failure parts during warranty application.
 - Any direct and/or indirect lose comes from warranty items.
 - Regarding to warranty, all seals, packing, O-rings and oil are excluded.



TANONG PRECISION TECHNOLOGY CO., LTD.

No.6, Fengming Rd., Daya Dist., Taichung City
428, Taiwan (R.O.C.)
Tel : +886-4-25662106
Fax: +886-4-25662109
web:www.tanong.com.tw
E-mail: info@tanong.com.tw

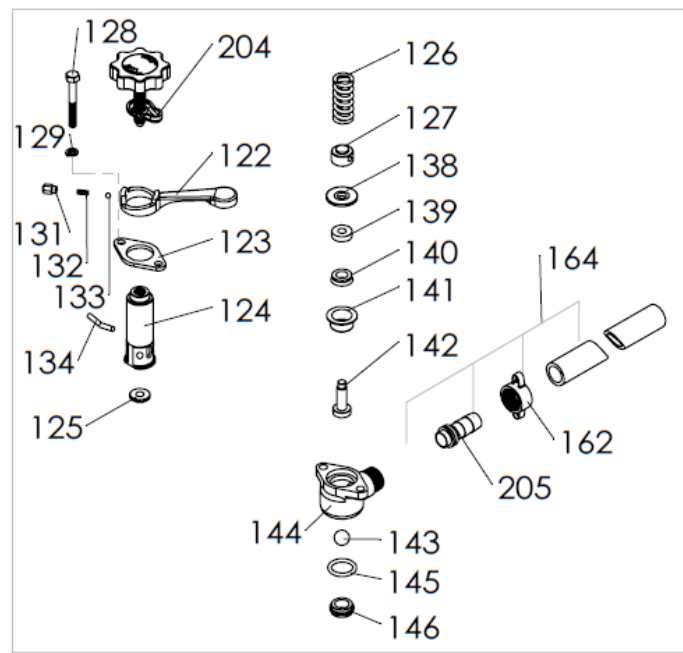
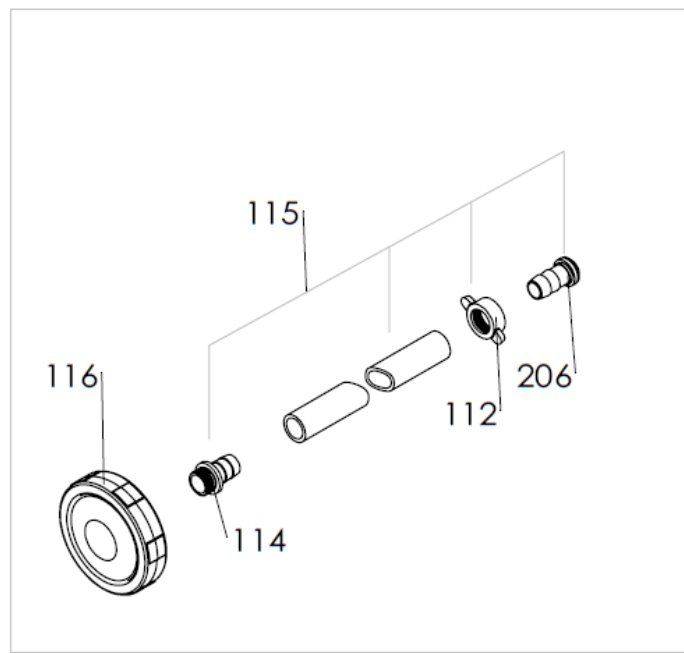
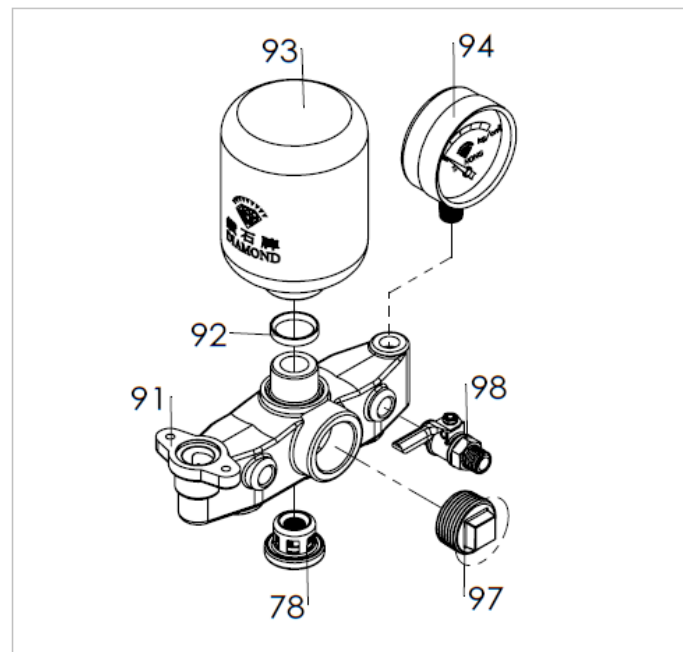
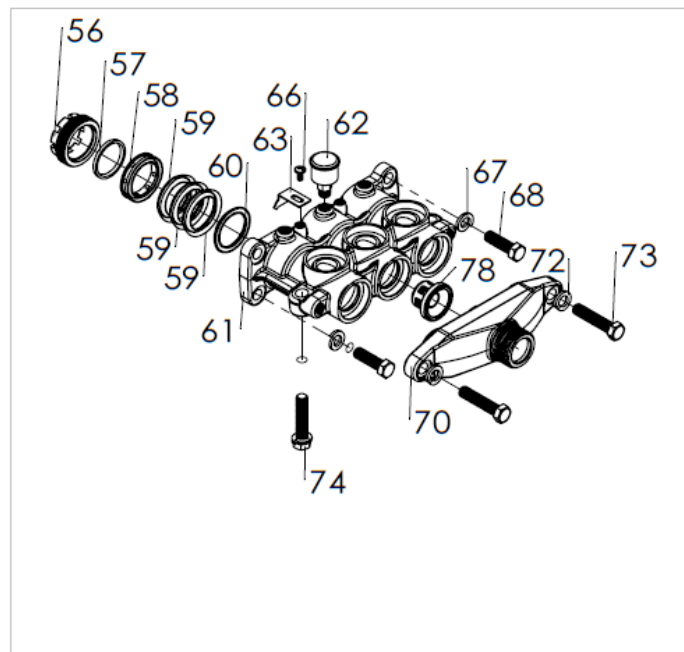
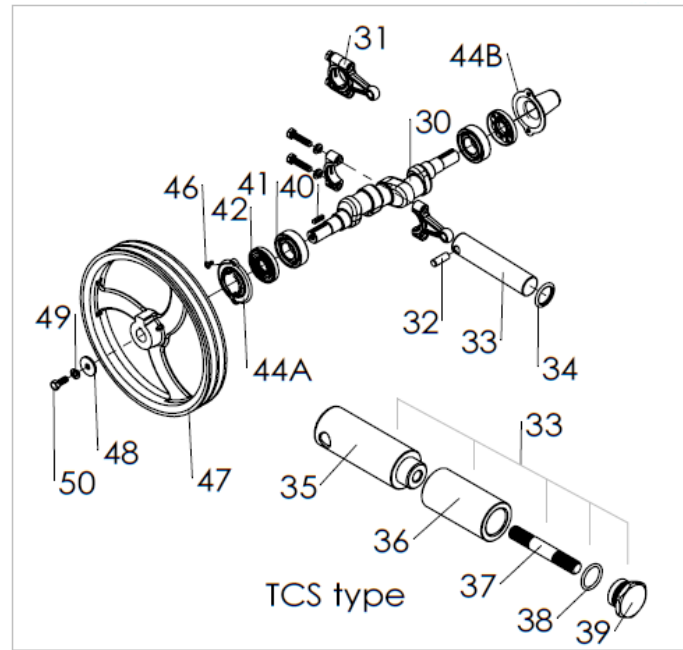
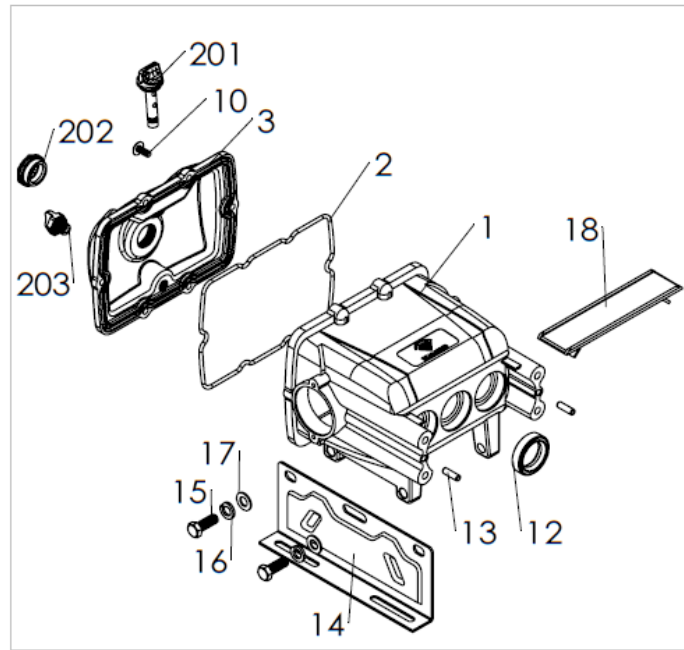

Pos.	Parts No.	Parts Name	Q'ty	Specification	Pos.	Parts No.	Parts Name	Q'ty	Specification
1	010-5800-242	Crank case	1		73	140-0308-003	Bolt	2	3/8"×1 3/4"
2	013-1000-000	Gasket, crank case	1		74	140-0308-004	Bolt	2	3/8"×55+S
3	011-1000-241	Cover, crank Case	1		78	080-2800-001	Valve Ass'y	6	
10	142-0600-003	Screw	6	6×15+S	91	050-5800-220	Discharge Metal	1	
12	130-5800-000	Oil Seal, plunger	3	30×42×10	92	041-2200-000	Packing	1	
13	012-2200-000	Pin	2		93	052-2801-252	Air Chamber	1	
14	018-2800-270	Stand, crank case	2		94	055-2200-101	Pressure Gauge	1	
15	140-0308-001	Bolt	4	3/8×1"	97	058-5800-130	Cap	1	1"
16	144-0308-001	Washer, Spring	4	3/8"	98	051-2800-000	Cock	2	
17	145-0308-001	Washer	4	3/8"×19	112	057-2800-000	Coupling	1	1"
18	016-2800-260	Plunger Cover	1		114	032-2800-260	Hose barb	1	1"
30	020-5800-220	Crank Shaft	1		115	A03-S010-085	Suction Hose	1	1"×8.5'
31	021-5800-240	Connecting Rod	3		116	033-2800-000	Strainer Ass'y	1	
32	023-5800-000	Plunger Pin	3		122	074-2800-000	Lever	1	
33	022-5800-002	Plunger	3		123	073-2800-000	Seat, Spring box	1	
	022-3580-000	Plunger Ceramic	3	TCS type	124	070-2800-000	Spring Box	1	
34	027-5800-000	Stopping Ring, Water	3		125	076-2800-000	Spring seat(upper)	1	
35	022-3580-001	Plunger Head	3	TCS type	126	078-2800-000	Spring	1	
36	022-3580-003	Ceramic Bush	3	TCS type	127	077-2800-000	Spring seat	1	
37	022-3750-102	Bolt	3	TCS type	128	143-0104-000	Bolt	2	1/4"×48
38	120-1620-000	O-Ring	3	16×2 TCS type	129	144-0600-001	Washer, Spring	2	M6
39	022-3580-004	Plunger Cap	3	TCS type	131	074-2800-003	CAP Nut	1	
40	025-2800-000	Key	1		132	074-2800-002	Spring	1	
41	024-2800-001	Bearing	2		133	074-2800-001	Steel Ball	1	
42	131-2800-000	Oil Seal, Crank Shaft	2	20×52×8	134	075-2800-000	Pin	1	
44A	026-2200-001	Cover, Oil Seal-A	1		138	124-2800-000	Packing	1	
44B	026-2200-002	Cover, Oil Seal-B	1		139	061-2800-000	Spindle Guide	1	
46	142-0316-001	Screw	4	3/16×3/8"	140	062-2800-000	Oil Seal	1	
47	A04-10A2-242	Pulley	1		141	063-2800-000	Box, oil seal	1	
48	145-2800-000	Washer	1		142	064-2800-210	Spindle	1	
49	144-0516-001	Washer, Spring	1	5/16"	143	067-2800-251	Ball Valve	1	
50	140-0516-001	Bolt	1	5/16×3/4"	144	060-2800-220	Overflow chamber	1	
56	044-5800-001	Adjusting ring	3		145	120-1824-000	O-Ring	1	18×3
57	041-5800-000	Grease Packing	3		146	068-2800-250	Ball Valve Seat	1	
58	042-5800-001	Grease Ring	3		162	057-1600-000	Coupling	1	1/2"
59	043-5800-001	V-Packing	9		164	A03-O004-085	Over Flow Hose	1	1/2"×8.5'
	043-5800-002	V-Packing	9		201	923-2204-002	Oil Plug & O-Ring	1	
60	045-5800-000	V-Packing Seat	3		202	924-1000-000	Oil Gauge &Gasket	1	PF3/4-14
61	040-5800-220	Cylinder	1		203	925-2200-001	Plug, Fuel Drain & Gasket	1	
62	046-2800-000	Grease Cup	3		204	934-2800-000	Screw & Fly Nut	1	
63	047-5800-000	Baffle	2		205	031-1600-002	Hose barb & Packing	1	1/2"
66	142-0316-001	Screw	2	3/16×3/8"	206	031-2800-002	Hose barb & Packing	1	1"
67	144-0308-001	Washer, Spring	4	3/8"	207	930-2800-000	Over Flow Ass'y	1	122-146 &204
68	140-0308-002	Bolt	4	3/8×1 1/4"	208	931-2800-000	Spring Box Ass'y	1	122-134 &204
70	030-5800-220	Suction Metal	1		209	932-2800-000	Body Over Ass'y	1	138-146
72	144-0308-001	Washer, Spring	2	3/8"					